

This article was downloaded by:

On: 22 January 2011

Access details: *Access Details: Free Access*

Publisher *Taylor & Francis*

Informa Ltd Registered in England and Wales Registered Number: 1072954 Registered office: Mortimer House, 37-41 Mortimer Street, London W1T 3JH, UK



The Journal of Adhesion

Publication details, including instructions for authors and subscription information:

<http://www.informaworld.com/smpp/title~content=t713453635>

Peel Strength of Aluminium-Aluminium Joints Bonded by Adhesive Based on Carboxylated Nitrile Rubber-Chlorobutyl Rubber Blend

Tinku Bhattacharya^a; S. K. De^a

^a Rubber Technology Centre, Indian Institute of Technology, Kharagpur, India

To cite this Article Bhattacharya, Tinku and De, S. K.(1992) 'Peel Strength of Aluminium-Aluminium Joints Bonded by Adhesive Based on Carboxylated Nitrile Rubber-Chlorobutyl Rubber Blend', *The Journal of Adhesion*, 39: 1, 1 – 13

To link to this Article: DOI: 10.1080/00218469208026534

URL: <http://dx.doi.org/10.1080/00218469208026534>

PLEASE SCROLL DOWN FOR ARTICLE

Full terms and conditions of use: <http://www.informaworld.com/terms-and-conditions-of-access.pdf>

This article may be used for research, teaching and private study purposes. Any substantial or systematic reproduction, re-distribution, re-selling, loan or sub-licensing, systematic supply or distribution in any form to anyone is expressly forbidden.

The publisher does not give any warranty express or implied or make any representation that the contents will be complete or accurate or up to date. The accuracy of any instructions, formulae and drug doses should be independently verified with primary sources. The publisher shall not be liable for any loss, actions, claims, proceedings, demand or costs or damages whatsoever or howsoever caused arising directly or indirectly in connection with or arising out of the use of this material.

Peel Strength of Aluminium-Aluminium Joints Bonded by Adhesive Based on Carboxylated Nitrile Rubber-Chlorobutyl Rubber Blend

TINKU BHATTACHARYA and S. K. DE^a

Rubber Technology Centre, Indian Institute of Technology, Kharagpur—721 302, India

(Received December 4, 1991; in final form April 27, 1992)

The peel strength of aluminium-aluminium joints bonded by an adhesive based on carboxylated nitrile rubber and chlorobutyl rubber was found to depend on surface topography and use of a silane primer. Anodization causes a marginal increase in bond strength while the silane primer improves the adhesive joint strength remarkably.

The peel strength was also found to be dependent on test conditions (test rate and temperature). The threshold peel strength value obtained by measurements at low peel rate and high test temperature was found to depend on the type of failure during peeling (cohesive or interfacial) which, in turn, is controlled by the presence of silica filler in the adhesive. Two different threshold values of peel strength were obtained: 60 N/m for interfacial failure (in silica-filled adhesive), 140 N/m for cohesive failure (in unfilled adhesive).

KEY WORDS Peel strength; aluminium-aluminium joints; carboxylated nitrile rubber; chlorobutyl rubber; anodization; silane primer; test rate; test temperature; interfacial failure; cohesive failure; threshold peel strength value

INTRODUCTION

It has been reported that a self-vulcanisable rubber blend based on chlorobutyl rubber (CIIR) and carboxylated nitrile rubber (XNBR)¹ can be used as a reusable dry adhesive for aluminium-aluminium bonding.² The peel strength of such composite was found to increase when silica filler was incorporated into the adhesive.³

Chemical and electrochemical surface pretreatments are known to produce aluminium oxide layers of varying thickness and chemical reactivity and it has been shown that mechanical interlocking between the polymer and the porous, thick oxide layer increases the adhesive bond strength.^{4,5}

Silane primers of the general structure (X₃SiRY) are widely used for enhancement of adhesive bond strength.^{6–11} X is a hydrolysable group, able to react with

^aTo whom correspondence should be addressed.

adherends such as metal, glass etc., and Y is an organofunctional group usually selected for reactivity with a given polymeric adhesive.

The peel strength as a function of the viscoelasticity of the polymeric adhesive (effect of test rate and temperature) has been studied.¹²⁻¹⁸

Peel strength thus depends on, among other factors, surface topography of adherend, use of silane primer and the test conditions (rate and temperature).⁴⁻¹⁸

In the present paper, we report the results of studies on the effects of the above factors on the peel strength of aluminium-aluminium joints bonded by the self-vulcanisable rubber blend of CIIR and XNBR.

EXPERIMENTAL

Materials

The aluminium foils (thickness 0.05 mm, hardness 52.7 V.P.N.) were obtained from INDAL, Bombay. The chlorobutyl rubber, grade 1168 (chlorine content 1.2% by wt, Mooney viscosity, ML(1+4) at 120°C, 50), was obtained from Exxon Chemical Company, U.S.A. The carboxylated nitrile rubber (Mooney viscosity, ML(1+4) at 120°C, 30) used was Krynac 231[®] of Polysar, Ltd., Canada. The precipitated silica (Vulcasil S) of surface area 160–170 m²/gm was obtained from Bayer, Germany. Vinyl trimethoxy silane (A-151) was obtained from Dow Corning, U.S.A. and γ -aminopropyl triethoxy silane (A-1100) was obtained from Union Carbide, U.S.A.

Preparation of the Rubber Blend

The 1:1 blend of CIIR and XNBR was prepared on a two-roll mill. The two-roll mill operating conditions are given in Table I. The CIIR was masticated for 1 min. The XNBR was then blended with the CIIR and further masticated for 8 mins. In the case of the silica-filled adhesive, the filler was added after 2 mins mastication of the rubber and the mixing continued for an additional 6 min. A blend thus prepared was ready for use as a bonding agent between the metal foils.

Sulphuric Acid Anodization (SAA)

We used the Alzak process for anodization.¹⁹ The anodization conditions are given in Table II. After anodizing, the Al foil was washed with tap water and cleaned with acetone.

TABLE I
Two-roll mill operating conditions

1. Manufacturer	SCHWABENTHAN, BERLIN
2. Type	Industrial Drive
3. Dimension of the roll	35 cm × 15 cm
4. Cooling system	Peripheral drilled holes
5. Ampere rating	78
6. Motor drive Power KW	4.8 each
7. Temperature	30°C

TABLE II
Conditions for sulphuric acid anodization (Alzak process)

Solution:	70 ml conc. sulphuric acid 930 ml dist. water
Cathode:	Stainless steel (25 cm × 25 cm)
Anode:	Al foil (5 cm × 5 cm)
Voltage:	20 V
Current density:	1.3 amp/dm ²
Time:	20 min
Temperature:	20°C

Use of Silane Primers

Two types of silane primers were used:

(i) γ -Aminopropyl triethoxy silane (γ -APS)

The Al foil was immersed for 30 min in a 1% aqueous solution of (γ -APS). Then air was blown on the Al foil to remove the excess water. A thin layer of primer was formed. This Al foil was used for making composites.

(ii) Vinyl trimethoxy silane (VTS)

A thin layer of silane primer was applied to cleaned Al foil (5 × 5 cm) and kept for one min in air. This silane-primed Al foil was used for making composites.

Preparation of the Composite

Aluminium foils were cut into 7.5 cm × 5.0 cm sizes and cleaned with acetone. 0.2 gm of the rubber blend was inserted between the two aluminium foils and the composites were moulded for different times at 180°C and 0.35 MPa moulding pressure. A part of the metal foil assembly was not filled with rubber and was kept outside the mould during moulding. This part was fixed with the grip of the Instron Universal Testing Machine during testing. The dimensions of the test specimen was 7.5 cm × 2.5 cm. The bonded region was 5.0 cm × 2.5 cm, as shown in Figure 1.

Effect of Testing Rate and Temperature

For our convenience in sample preparation we used larger-sized Al foil (15 cm × 20 cm) and 3.0 gm of rubber. The bonded area was 15 cm × 15 cm and 15 cm × 5 cm was kept outside the mould for gripping in the Instron UTM. Before putting in the mould 3 gm of rubber was passed four times through the two-roll mill at the closest nip gap (0.3 mm) to produce a thin rubber layer. Then the composites were prepared as described earlier. The dimensions of the test specimen are shown in Figure 1. Details of the method were described earlier.²

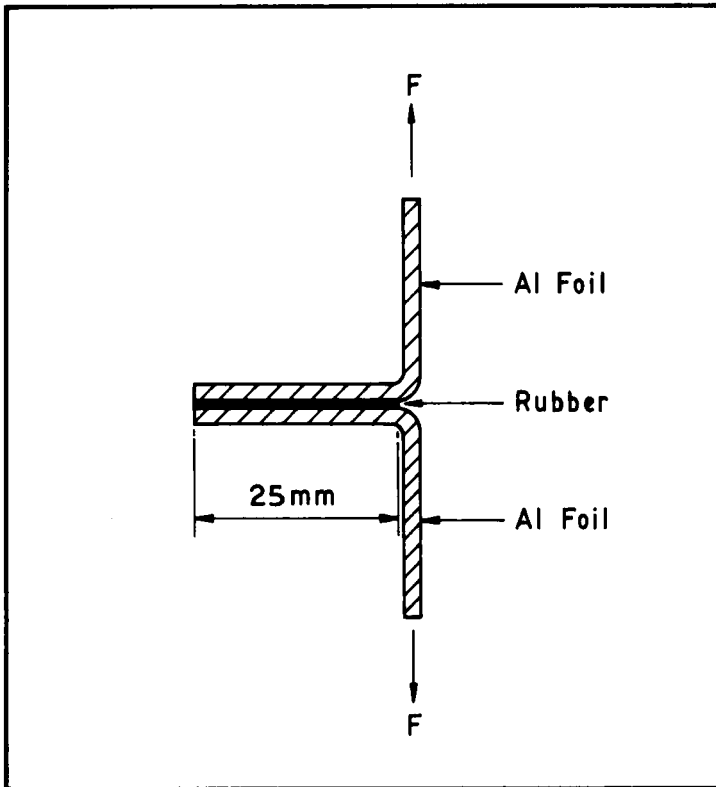

FIGURE 1 Schematic diagram of the test specimen.

Composition of the Adhesives

The compositions of the adhesives were chosen on the basis of our earlier work^{2,3} (Table III). For unfilled adhesive three moulding times (5 min, 30 min and 60 min) and for the silica-filled system one moulding time (60 min) was chosen. These composites were tested at different rates and temperatures to show the viscoelastic effect on adhesive joint strength.

TABLE III
Composition of the adhesives

Composition of the adhesives	Moulding time (min)	Peel strength ^a (N/m)	Mode of failure during peeling
1:1 blend of XNBR and CIIR	5	4,800	Rubber-Rubber
	30	7,200	Rubber-Rubber
	60	960	Rubber-Metal
1:1 Blend plus 20 phr ^b silica	60	7,680	Rubber-Metal

^aMoulding temperature 180°C; Moulding Pressure 0.35 Mpa Test rate 50 mm/min; Test temperature 25°C

^bParts per hundred gm of rubber blend

Determination of 180° Peel Strength

The 180° peel strength was determined in accordance with ASTM D413 using an Instron Universal Testing Machine, model 1195. The test specimen was fixed horizontally to the grip of the Instron machine using the non-bonded parts of the metal foils.

The average peel strength in terms of force/width was calculated from the plot of force *versus* displacement curve obtained in the Instron machine according to the formula:^{2,3,20,21}

$$\text{Peel strength} = 2F/w \quad (1)$$

F = Peel force in Newtons and w = width of the specimen in meters.

The peel strengths at higher temperatures were determined by attaching a temperature cabinet to the Instron UTM.

RESULTS AND DISCUSSION

SEM photographs of the “as-received” and anodized Al surfaces are shown in Figures 2(a) and 2(b), respectively. Anodizing of the Al surface produces a porous Al₂O₃, which increases mechanical interlocking with the adhesive. Table IV shows that anodization caused a marginal improvement in adhesive joint strength in both unfilled and silica-filled adhesives.

However, γ -APS primer caused a significant improvement in bond strength for unfilled and filled adhesives. But with increase in moulding time, peel strength decreases and cohesive failure changes to a combination failure (rubber-rubber and rubber-metal).

VTS primer also improves the adhesive joint strength. The strength at first increases with the moulding time and then decreases with the change-over of cohesive failure to combination failure (Table IV). Its effectiveness is greater than that of γ -APS.

The increase in bond strength by the application of silane primers has been studied by several workers.^{13–18} These studies are mainly concentrated on epoxy adhesives and aluminium surfaces. They suggested that silane primer hydrolyzes to form a silanol group, which polymerises to give a polysiloxane network on the Al surface. This silanol group reacts with the Al surface oxide to form an Si—O—Al linkage or H-bonds.^{13–18} Aqueous solutions of amino silane react with the Al surface at room temperature but vinyl silane requires a high temperature to react with the surface oxide on Al. These silane primers react with the adhesive either by chemical linking or physically, say, by interdiffusion between the polysiloxane network and the polymeric adhesive. Here it is expected that γ -APS will chemically react with XNBR through the NH₂ group, whereas VTS will form a physical bond with the CIIR through the vinyl group.

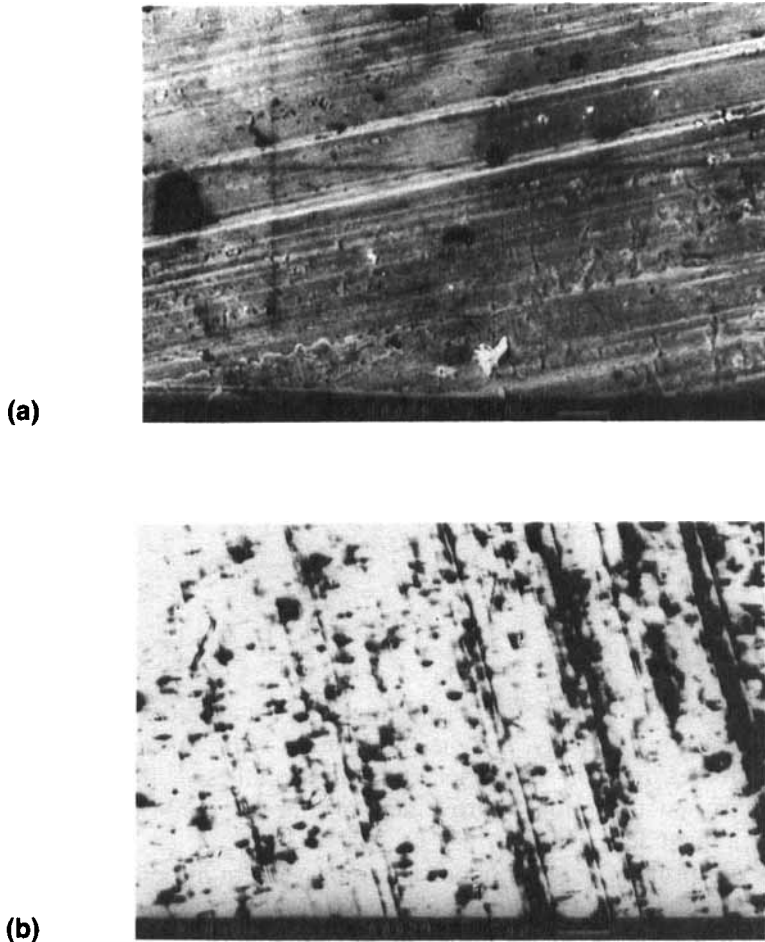

FIGURE 2 SEM photograph showing (a) Al surface and (b) anodized Al surface.

Effect of Peel Rate at Room Temperature

Figure 3 shows that the peel strength increased with the peel rate as long as the locus of failure was of the cohesive type. Beyond a critical peel rate, there was a concomitant decrease in the peel strength as the mode of failure changed from cohesive (rubber-rubber) to interfacial (metal-rubber). Once the interfacial failure started, the peel strength became independent of peel rate. Figure 3 also shows dependence of the peel strength and the critical peel rate on moulding time. The higher the moulding time, the lower was the critical peel rate for change over from cohesive to interfacial failure.

For adhesive containing 20 phr of filler, interfacial failure occurred at all peel rates (Fig. 4).

TABLE IV
Dependence of peel strength on Al surface topography and silane primers

Identification of the composites	Moulding time (min)	Peel strength (N/m)	Nature of failure during peeling
1. Unfilled adhesive on acetone cleaned Al foil	5	4,400	Rubber-rubber
	20	1,600	Combination of rubber-rubber and rubber-metal
	30	880	Rubber-metal
	60	480	Rubber-metal
2. Silica-filled adhesive on acetone cleaned Al foil	5	5,440	Rubber-rubber
	20	2,560	Rubber-metal
	30	1,820	Rubber-metal
	60	860	Rubber-metal
3. Unfilled adhesive on anodized Al foil	5	4,720	Rubber-rubber
	20	2,240	Combination of rubber-rubber and rubber-metal
	30	1,040	Combination of rubber-rubber and rubber-metal
4. Silica-filled adhesive on anodized Al foil	5	5,500	Rubber-rubber
	20	2,700	Combination of rubber-rubber and rubber-metal
	30	2,080	Rubber-metal
	60	980	Rubber-metal
5. Unfilled adhesive on -APS primed Al foil	5	5,040	Rubber-rubber
	20	1,920	Combination of rubber-rubber and rubber-metal
	30	1,120	Combination of rubber-rubber and rubber-metal
6. Silica-filled adhesive on -APS primed Al foil	5	6,720	Rubber-rubber
	20	3,250	Combination of rubber-rubber and rubber-metal
	30	2,250	Combination of rubber-rubber and rubber-metal
	60	1,120	Combination of rubber-rubber and rubber-metal
7. Unfilled adhesive on VTS primed Al foil	5	4,480	Rubber-rubber
	20	4,980	Rubber-rubber
	30	1,340	Combination of rubber-rubber and rubber-metal
	60	750	Combination of rubber-rubber and rubber-metal
8. Silica-filled adhesive on VTS primed Al foil	5	5,400	Rubber-rubber
	20	6,240	Rubber-rubber
	30	2,490	Combination of rubber-rubber and rubber-metal
	60	1,280	Combination of rubber-rubber and rubber-metal

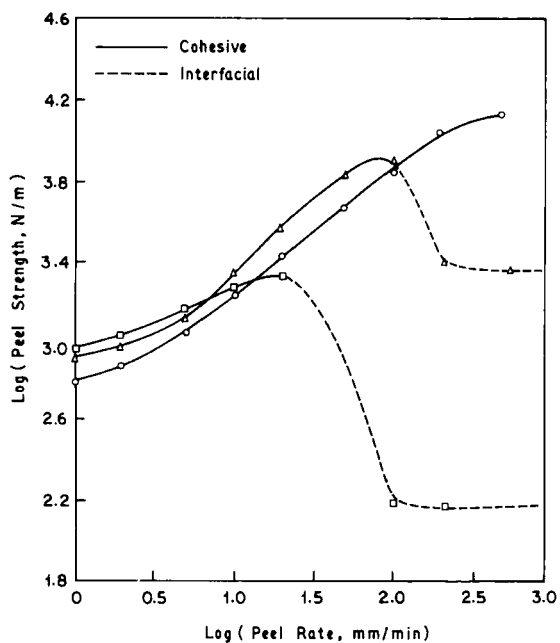

FIGURE 3 Peel strength vs. peel rate plot for unfilled adhesive systems (\circ 5 min. moulding time, \triangle 30 min. moulding time, \square 60 min. moulding time).

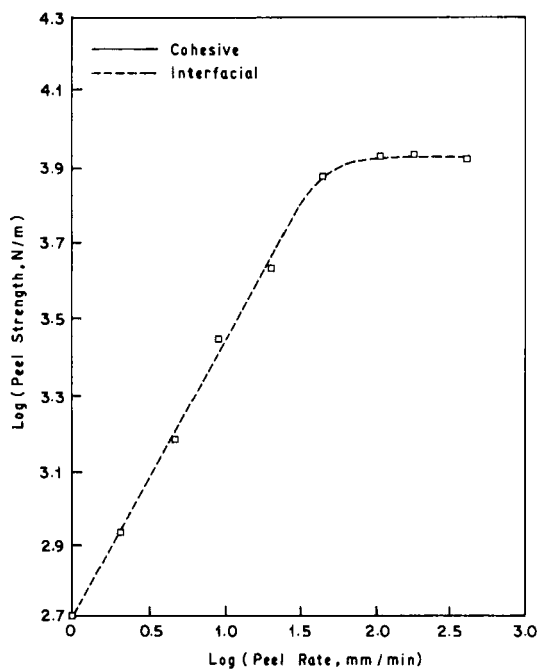

FIGURE 4 Peel strength vs. peel rate plot for silica-filled adhesive.

Effect of Testing Temperature and Peel Rate

At low peel rate and high test temperature, peel energy dissipation through the viscoelastic medium is reduced. The measured work of adhesion may then be regarded as an inherent property of the interface and be called the threshold detachment energy, to distinguish it from the higher value obtained under test conditions of lower temperatures and higher rates of peel.¹⁶

Figures 5(a) and 5(b) represent the rate dependence of peel strength for the unfilled adhesive system at different test temperatures (25°, 50°, 70° and 100°C). As the test temperature increased, the rate of change of peel strength with peel rate decreased due to the decrease in the viscoelastic effect of the adhesive. When the test temperature was 25°C, the moulding time was found to influence the peel strength values. But there was no change in peel strength with moulding time when the test temperature was 50°C. At 70°C and 100°C, the peel strength values were independent of moulding time and, furthermore, at low rate of separation the strength values merged to the threshold value of 140 N/m. At high test temperature the peel strength was almost independent of the rate and this indicated the absence of a viscoelastic effect.

Figure 6 represents the 20 phr silica filler loaded adhesive system at a moulding time of 60 min. Interfacial failure occurred at low peel rates and test temperatures. In this case, high silica filler concentration produced a very stiff adhesive and the resulting adhesive bond strength was low. Consequently, failure occurred at the interface. The threshold peel strength value obtained was 60 N/m, which corresponds to the interfacial bond strength between the aluminium surface and the silica-filled adhesive. The bond strength was much higher than the secondary forces of attraction and the high value indicated that there must be a chemical interaction at the aluminium-adhesive interface.³ It has been reported that aluminium reacts with silica to form an Si—O—Al linkage.^{3,7}

The principle of time-temperature superposition was applied by using the WLF relation. The reduced rates of peeling, Ra_T , were calculated for each rate, R , and testing temperature, T , by means of the universal WLF equation for temperature above T_g

$$\log a_T = -8.86 (T - T_r) / [101.6 + (T - T_r)] \quad (2)$$

where $T_r = 298^\circ\text{K}$

Both unfilled and filled adhesive followed the WLF equation {Figs. 7(a) and 7(b)}.

CONCLUSIONS

Al-Al joint strength produced by an adhesive based on chlorobutyl rubber and carboxylated nitrile rubber was determined. It was observed that sulphuric acid anodization of Al did not improve adhesive joint strength significantly, whereas silane primers (γ -aminopropyl triethoxy silane and vinyl trimethoxy silane) improved the adhesive bond strength remarkably.

The measured peel strength of the aluminium-aluminium joint was found to

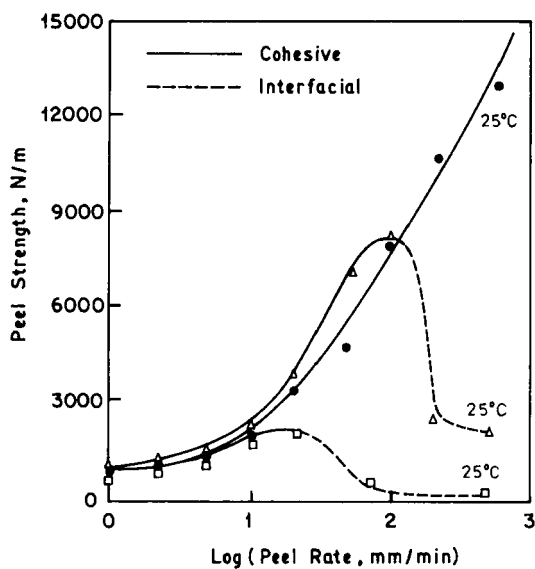

(a)

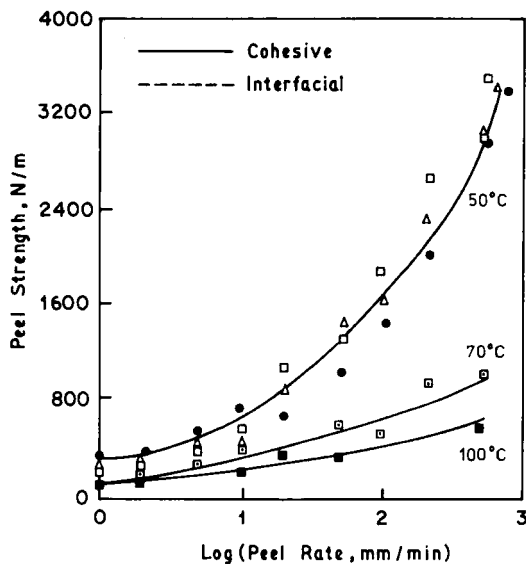

(b)

FIGURE 5 Variation of peel strength with log (peel rate) at different test temperatures for unfilled adhesive systems. (a) test temperature: 25°C, ● 5 mins moulding time, △ 30 mins moulding time, □ 60 mins moulding time. (b) test temperature: 50°, 70° and 100°C. At 50°C, ● 5 min. moulding time, △ 30 min. moulding time, □ 60 min. moulding time. At 70°C, □ moulding time of 5, 30 and 60 min. (The peel strength at a particular peel rate was independent of moulding time). At 100°C, ■ moulding time of 5, 30 and 60 min. (The peel strength at a particular peel rate was independent of moulding time).

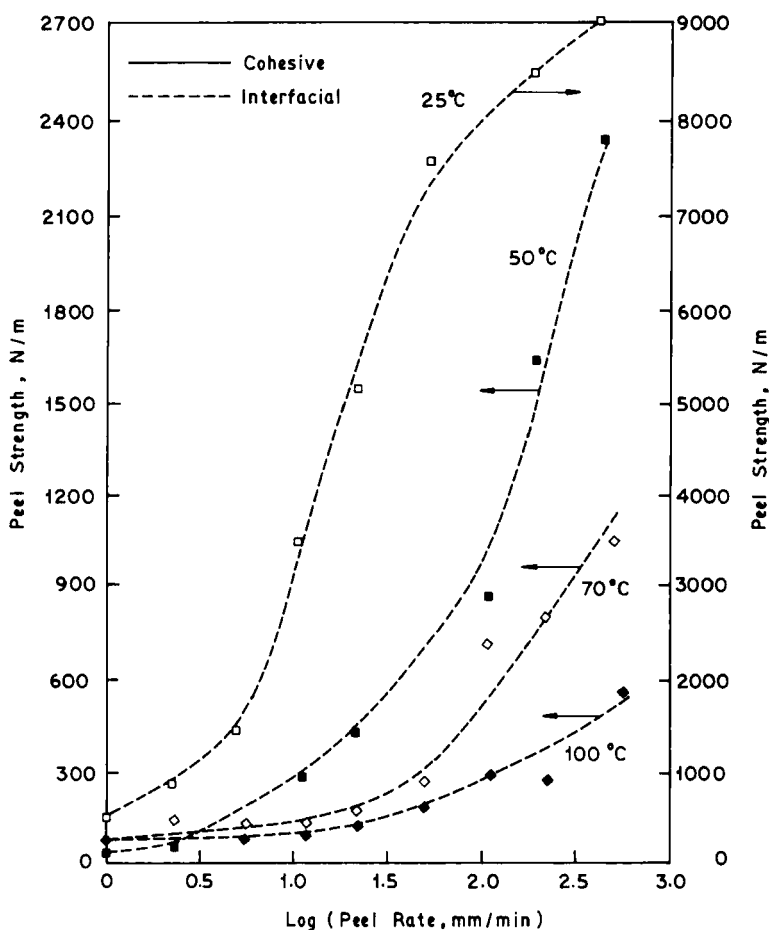

FIGURE 6 Plot of peel strength vs. log (peel rate) at different test temperatures for adhesive with 20 phr silica filler.

depend on test temperature and peel rate. The minimum peel strength, termed the threshold value, obtained at high temperature and low peel rate was found to depend on the adhesive composition. Cohesive failure occurred in the case of the unfilled adhesive and its threshold peel strength was 140 N/m. When the silica filler loading was 20 phr, the failure was of the interfacial type and the threshold peel strength value was 60 N/m.

References

1. Tinku Bhattacharya and S. K. De, *European Polym. J.* **27**, 1065 (1991).
2. Tinku Bhattacharya, B. K. Dhindaw and S. K. De, *J. Adhesion*, **34**, 45 (1991).
3. Tinku Bhattacharya, B. K. Dhindaw and S. K. De, *J. Adhesion Sci. Technol.* in press (1992).

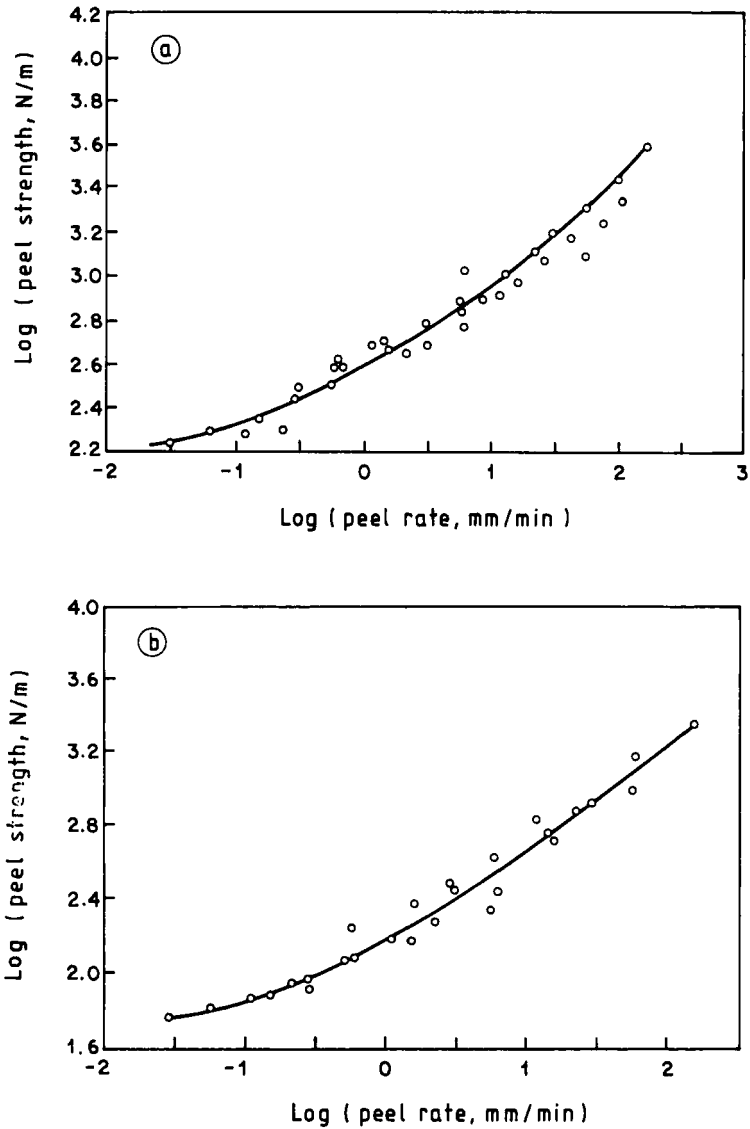

FIGURE 7 Plot of WLF equation for filled and unfilled adhesive: (a) unfilled adhesive; (b) filled adhesive.

4. W. Brockmann, O. D. Hennemann, H. Kollek and C. Matz, *Int. J. Adhesion Adhesives*, **6**, 115 (1986).
5. J. D. Venables, *J. Mat. Sci.*, **19**, 2431 (1984).
6. L. Ulren, T. Hjertberg and H. Ishida, *J. Adhesion*, **31**, 117 (1990).
7. L. P. Buchwalter, *J. Adhesion Sci. Technol.*, **4**, 697 (1990).
8. K. W. Allen and N. G. Stevens, *J. Adhesion*, **14**, 137 (1982).
9. D. J. Ondrus, F. J. Boerio and K. J. Grannen, *J. Adhesion*, **29**, 27 (1989).
10. F. J. Boerio and D. J. Ondrus, *J. Colloid Interface Sci.*, **124**, 349 (1988).

11. E. P. Plueddemann, *Silane Coupling Agents* (Plenum Press, New York, 1982).
12. A. N. Gent, *Int. J. Adhesion Adhesives*, **1**, 175 (1981).
13. Takashi Igarashi, *J. Polym. Sci., Phys. Ed.*, **13**, 2129 (1975).
14. Y. Urahama, *J. Adhesion*, **31**, 47 (1989).
15. S. S. Voyutskii, *Autohesion and Adhesion, Polymer Reviews, Vol. 4* (Interscience, New York, 1963), Chap. VI.
16. R. J. Chang and A. N. Gent, *J. Polym. Sci., Phys. Ed.*, **19**, 1619 (1981).
17. A. Tager, *Physical Chemistry of Polymers*, 2nd Ed. (Mir Publishers Moscow, 1972), p. 186.
18. D. W. Aubrey, in *Adhesion-3*, K. W. Allen, Ed. (Applied Science Publishers, London, 1977), Chap. 12, p. 191.
19. W. J. Tegart, *The Electrolytic and Chemical Polishing of Metals in Research and Industry* (Pergamon Press, London, 1959), p. 85.
20. Tinku Bhattacharya and S. K. De, *J. Adhesion Sci. Technol.* (in press).
21. Tinku Bhattacharya, B. K. Dhindaw and S. K. De, *J. Adhesion* (submitted).